

8 7 6 5 4 3 2 1

F

F

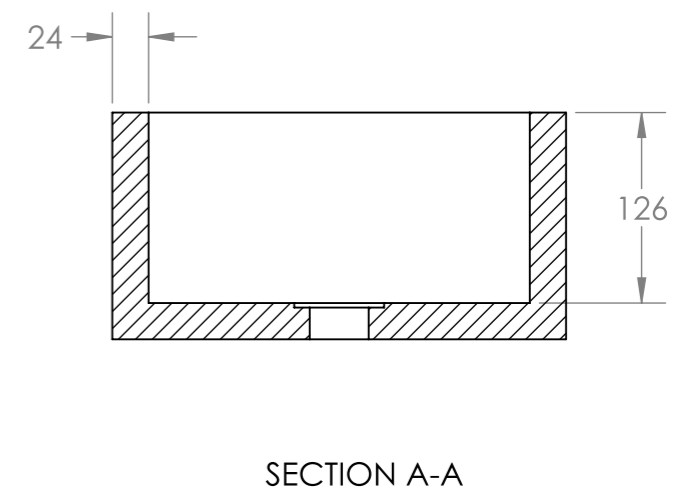
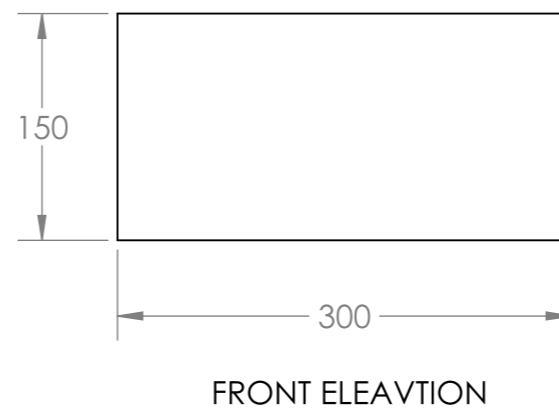
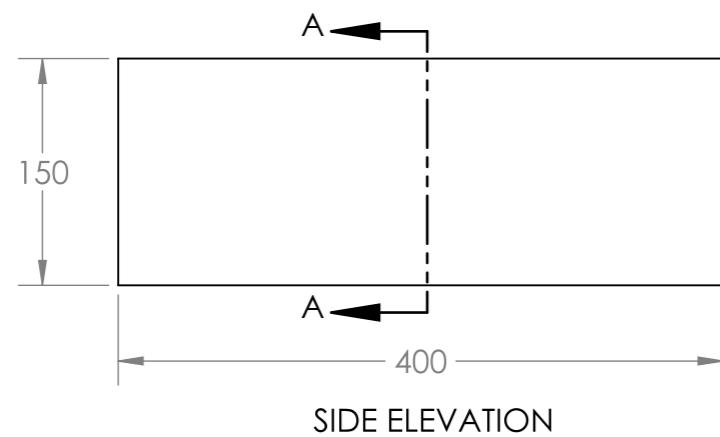
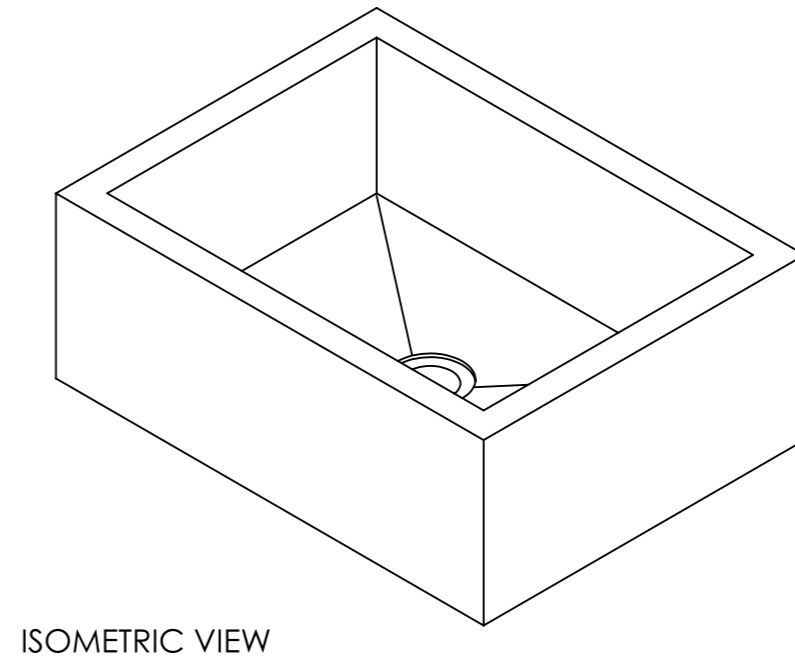
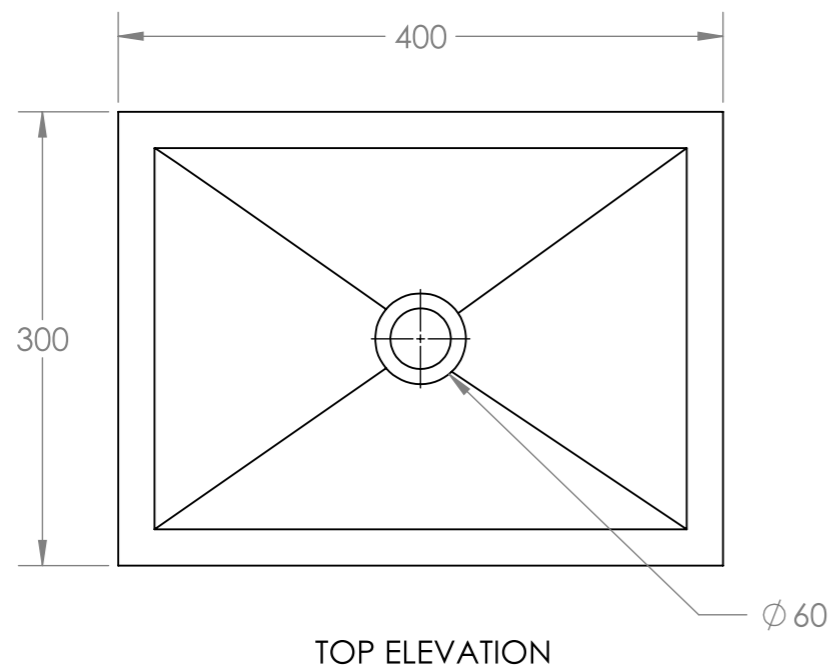

C

C

B

B

THE  
**Poured**  
PROJECT

|   |  |  |         |  |                                    |  |                      |  |              |  |  |
|---|--|--|---------|--|------------------------------------|--|----------------------|--|--------------|--|--|
| UNLESS OTHERWISE SPECIFIED:<br>DIMENSIONS ARE IN MILLIMETERS<br>SURFACE FINISH:<br>TOLERANCES:<br>LINEAR:<br>ANGULAR: |  |  | FINISH: |  | DEBURR AND<br>BREAK SHARP<br>EDGES |  | DO NOT SCALE DRAWING |  | REVISION     |  |  |
| DRAWN   |  |  | NAME    |  | SIGNATURE                          |  | DATE                 |  | TITLE:       |  |  |
| CHK'D   |  |  |         |  |                                    |  |                      |  |              |  |  |
| APPV'D  |  |  |         |  |                                    |  |                      |  |              |  |  |
| MFG   |  |  |         |  |                                    |  |                      |  |              |  |  |
| Q.A   |  |  |         |  |                                    |  | MATERIAL:            |  | DWG NO.      |  |  |
|   |  |  |         |  |                                    |  |                      |  | A3           |  |  |
|   |  |  |         |  |                                    |  | WEIGHT:              |  | SCALE:1:5    |  |  |
|   |  |  |         |  |                                    |  |                      |  | SHEET 1 OF 1 |  |  |

**MINI RECTANGLE BASIN**

A

A

8 7 6 5 4 3 2 1